

# IDROSTOP

Hydrophilic expandable rubber section for watertight construction joints

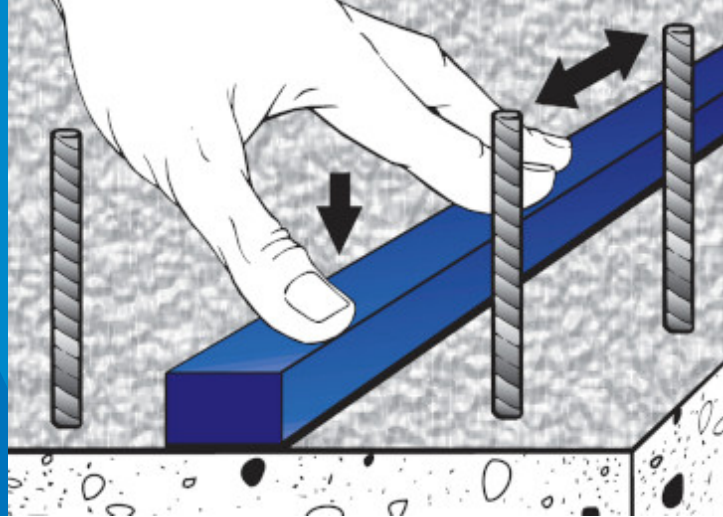

## WHERE TO USE

For creating water tight construction joints in civil, industrial, and hydraulic construction.

### Some application examples

- Waterproof joints between concrete beds and elevation walls.
- Contact joints between different types of materials, e.g. PVC or steel tubing going through poured concrete in swimming pools, sewage-treatment tanks, reservoirs, and hydraulic projects in general.
- Waterproof construction joints where conventional water-stop cannot be installed easily and securely because of the high density of the reinforcing.
- Waterproof construction joints in tunnels, dams and hydraulic projects including reservoirs for drinking water.

## TECHNICAL CHARACTERISTICS

**Idrostop** is a pre-formed rubber profile, with an acrylic polymer base specially designed to form watertight construction joints in construction up to a hydraulic pressure of 5 atm.

**Idrostop** is available in 3 sizes, 20x10 mm, 20x15 mm and 20x25 mm, labelled **Idrostop 10**, **Idrostop 15** and **Idrostop 25**.

**Idrostop does not contain bentonite.**

Unlike other materials that tend to lose efficiency following repeated cycles of expansion and contraction, **Idrostop** maintains its properties unchanged even in the presence of aggressive water such as salt water (sea water), and water in sewage treatment plants and sewers.

**Idrostop** is stable at temperatures between  $-30^{\circ}\text{C}$  and  $+50^{\circ}\text{C}$ .

## RECOMMENDATIONS

- **Idrostop** cannot be installed if the structure is immersed in water at the time of application. Remove any free water from the surface and wait several hours before installing the strip.
- **Idrostop** cannot be used if the surface of the installation is heavily contaminated with acids or solvents. Clean the surface thoroughly and consult the MAPEI Technical Assistance.

## APPLICATION PROCEDURE

### Substrate preparation

The surface of the concrete must be clean and solid when **Idrostop** is installed.

Remove any cement laitance with a brush and sweep away any deposits that may have been left during pouring. **Idrostop** can even be applied on slightly damp surfaces.

## Installation

**Idrostop** can be applied on concrete, metal, PVC, with **Idrostop Mastic**, a ready-to-use, solvent-free single component adhesive based on MS polymers.

**Idrostop Mastic** is available in 300 ml cartridges.

After extrusion the mastic becomes a thixotropic paste easily applied vertically and horizontally. It reticulates with moisture to form a flexible product at temperatures from +10°C to +40°C.

Make a hole in the cartridge above the threads and screw in the nozzle, cutting an opening with a diameter of 5 mm at a 45° angle. Insert the cartridge into a normal gun and extrude the adhesive onto the surface of an **Idrostop** section that has been cut to size beforehand, or directly onto the concrete.

Then press the **Idrostop** onto the substrate, moving it slowly in all directions to make it adhere thoroughly at all points without exerting traction.

Forming corners or seams does not require any special procedure. Simply align the pieces of **Idrostop** together and their subsequent expansion will ensure a perfect seal against water pressure.

Very long pieces can be installed in vertical mechanically attaching the top end of the **Idrostop** with screws or nails, extruding a line of adhesive directly onto the substrate.

**Idrostop** can also be solely attached mechanically with screws or nails placed in a row along the strip, spaced not more than 25 cm apart, to ensure thorough contact with the substrate.

Concrete can be poured immediately after the **Idrostop** is installed if attached mechanically with screws and nails. If **Idrostop** has been attached with **Idrostop Mastic**, wait 24 hours before pouring the concrete.

The waiting time can be shortened, if necessary, but a minimum of 4 hours must pass after installing the **Idrostop Mastic**. In this case it is recommended that nails or screws be placed every 1 meter to prevent the **Idrostop** from moving during the pour.

The thickness of the protection pour of **Idrostop** should not be less than 8 cm.

## Cleaning

Wet **Idrostop Mastic** can be removed from tools with common solvents (ethyl acetate, benzene, toluene). Once reticulation is complete, tools can only be cleaned mechanically.

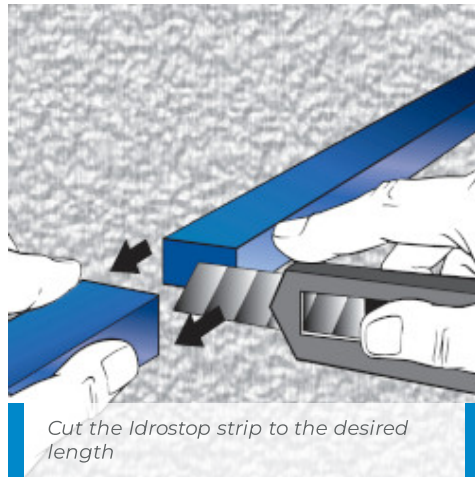

*Cut the Idrostop strip to the desired length*



*Apply Idrostop Mastic evenly on the Idrostop or directly to the substrate*

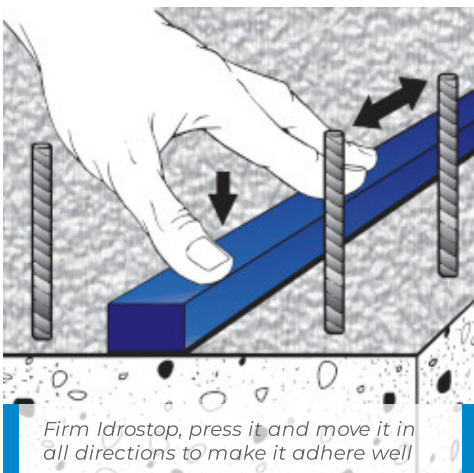

*Firm Idrostop, press it and move it in all directions to make it adhere well*

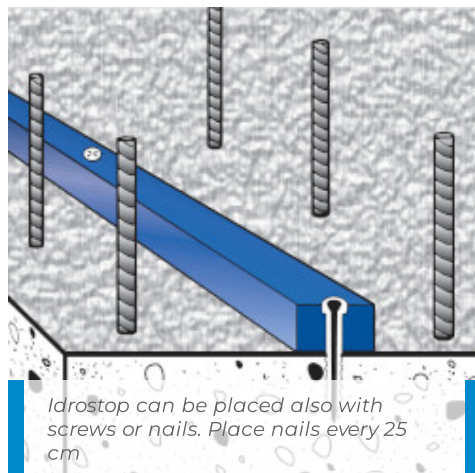

*Idrostop can be placed also with screws or nails. Place nails every 25 cm*

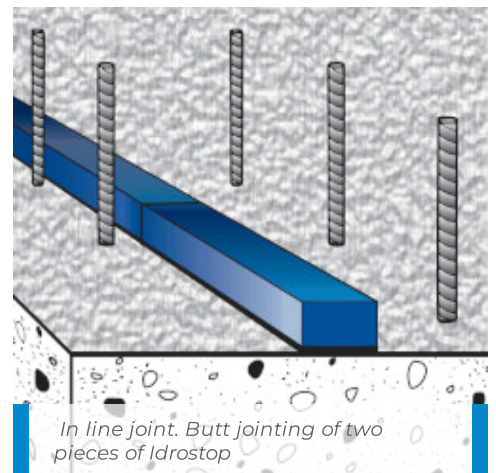

*In line joint. Butt jointing of two pieces of Idrostop*



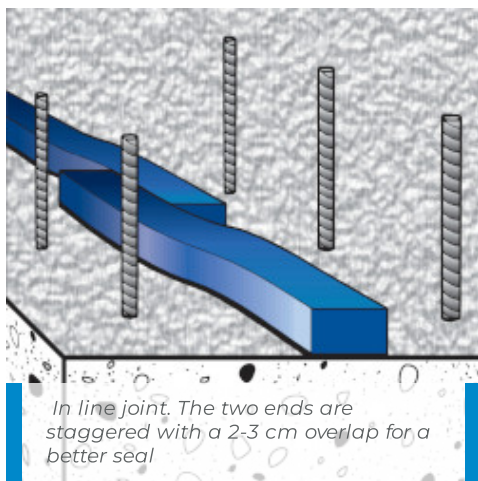

In line joint. The two ends are staggered with a 2-3 cm overlap for a better seal

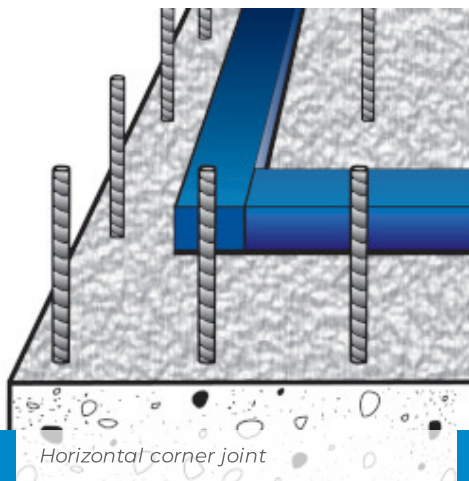

Horizontal corner joint

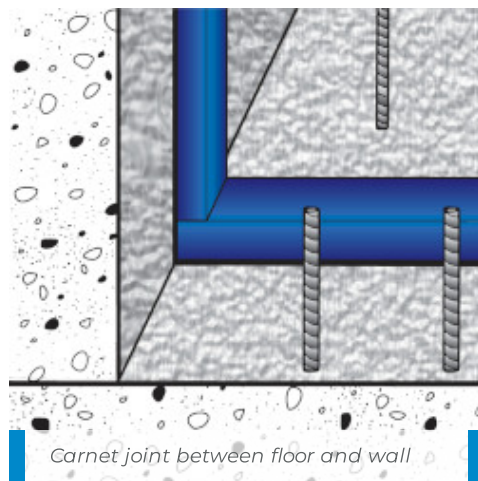

Corner joint between floor and wall

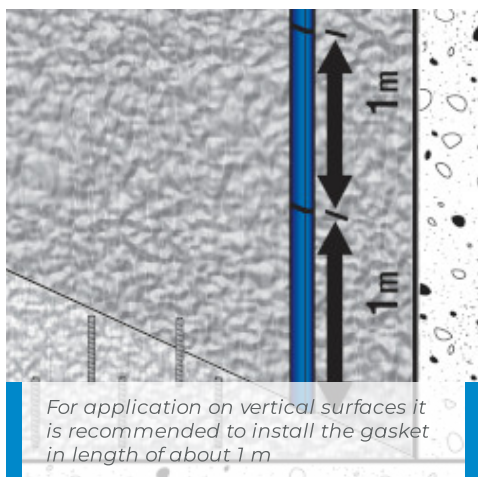

For application on vertical surfaces it is recommended to install the gasket in length of about 1 m

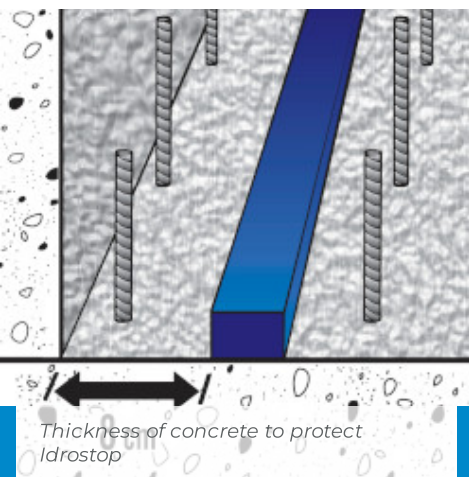

Thickness of concrete to protect Idrostop

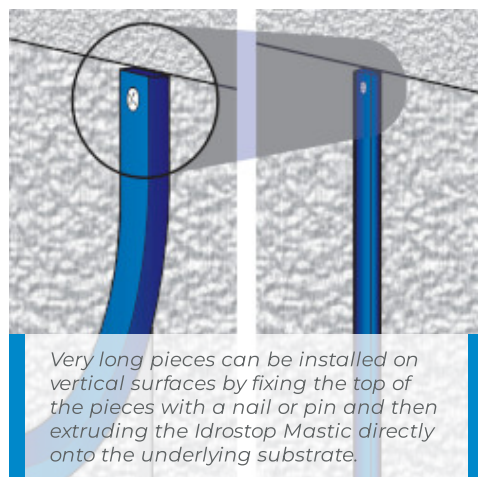

Very long pieces can be installed on vertical surfaces by fixing the top of the pieces with a nail or pin and then extruding the Idrostop Mastic directly onto the underlying substrate.

## PACKAGING

Idrostop is available in 3 sizes in cartons:

- **Idrostop 10** (20x10 mm): six 10 m rolls.
- **Idrostop 15** (20x15 mm): six 7 m rolls.
- **Idrostop 25** (20x25 mm): six 5 m rolls.

## STORAGE

Idrostop can be stored for 36 months in a dry place at temperatures between +10°C and +40°C.

## SAFETY INSTRUCTIONS FOR PREPARATION AND APPLICATION

Idrostop is an article and referring to the current European regulations (Reg. 1906/2007/CE - REACH) does not require the preparation of the Safety Data Sheet. During use it is recommended to wear protective gloves and goggles and follow the safety requirements of the workplace.

PRODUCT FOR PROFESSIONAL USE.

## TECHNICAL DATA (typical values)

### PRODUCT IDENTITY

Colour:

blue

Available sizes:

20x10 mm (**Idrostop 10**)

20x15 mm (**Idrostop 15**)

20x25 mm (**Idrostop 25**)

Density (g/cm<sup>3</sup>):

approx. 1.5

Solubility in water:	insoluble
Principle properties:	expands when in contact with water

## APPLICATION DATA

Waiting time before pouring concrete if the installation has been carried out with Idrostop Mastic:	24 hours
Waiting time before pouring concrete if the installation has been carried out screws and nails:	no waiting time required
Consumption of Idrostop Mastic:	approximately 300 ml per 5 linear metres of <b>Idrostop 10</b> , <b>Idrostop 15</b> and <b>Idrostop 25</b>

## FINAL PERFORMANCES

Expansion in water (%):	
– after 24 hours:	approximately 45
– after 2 days:	approximately 70
– after 3 days:	approximately 82
– after 7 days:	approximately 120
Impermeability:	up to 5 atm
Elongation % according to ASTM 638 M-89 (%):	70-100
Shore hardness according to DIN 53505:	25-30

## WARNING

Although the technical details and recommendations contained in this product data sheet correspond to the best of our knowledge and experience, all the above information must, in every case, be taken as merely indicative and subject to confirmation after long-term practical application; for this reason, anyone who intends to use the product must ensure beforehand that it is suitable for the envisaged application. In every case, the user alone is fully responsible for any consequences deriving from the use of the product. Please refer to the current version of the Technical Data Sheet, available from our website [www.mapei.com](http://www.mapei.com)

## LEGAL NOTICE

The contents of this Technical Data Sheet (“TDS”) may be copied into another project-related document, but the resulting document shall not supplement or replace requirements per the TDS in effect at the time of the MAPEI product installation. For the most up-to-date TDS and warranty information, please visit our website at [www.mapei.com](http://www.mapei.com). ANY ALTERATIONS TO THE WORDING OR REQUIREMENTS CONTAINED IN OR DERIVED FROM THIS TDS SHALL VOID ALL RELATED MAPEI WARRANTIES.

### Mapei S.p.A.

Via Cafiero, 22, 20158, Milano



+39-02-376731



[www.mapei.com](http://www.mapei.com)



[mapei@mapei.it](mailto:mapei@mapei.it)

411-1-2024 en (IT)

Any reproduction of texts, photos and illustrations published here is prohibited and subject to prosecution

