

ADMIXTURES for CONCRETE

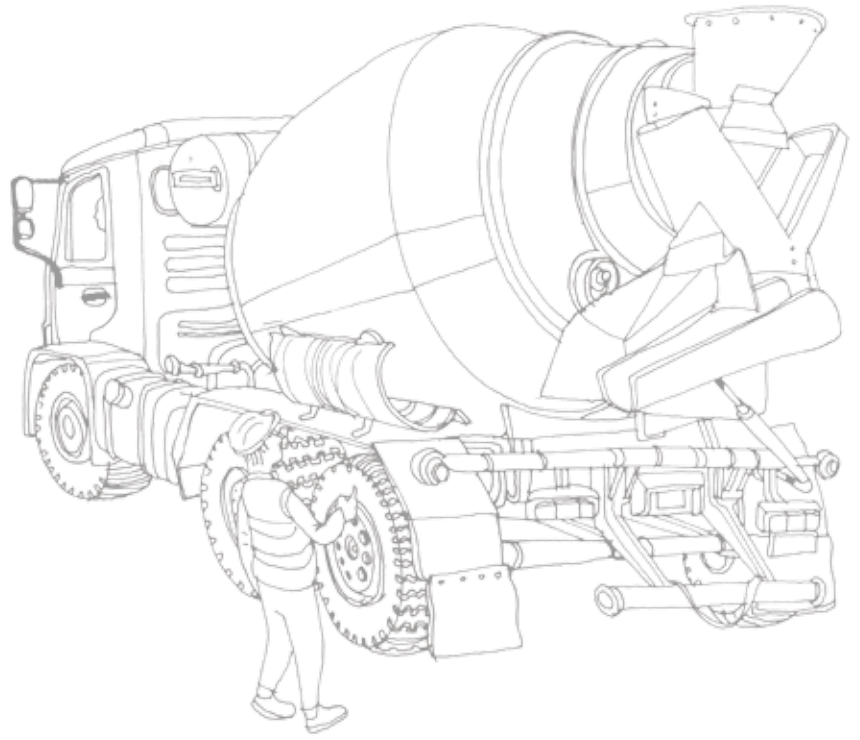

Index by sector

Page	2	CE marking for admixtures
Page	3	Classification of admixtures for concrete
Page	4	Dynamon XTend W superplasticising admixtures with long maintenance of workability
Page	5	Dynamon XTend W superplasticising admixtures with long maintenance of workability
Page	6	Dynamon XTend W superplasticising admixtures with long maintenance of workability
Page	7	Chronos super-plasticisers
Page	8	High-performance super-plasticisers for ready-mixed concrete Dynamon SR admixtures
Page	10	High-performance super-plasticisers for ready-mixed concrete Dynamon SX admixtures
Page	12	Multi-purpose super-plasticisers for ready-mixed concrete
Page	13	Conventional plasticisers and super-plasticisers for ready-mixed concrete
Page	14	High-performance super-plasticisers for precast concrete elements
Page	15	Super-plasticisers for industrial floors
Page	16	Setting and hardening retardants
Page	17	Setting and hardening accelerators
Page	18	Pozzolanic action admixtures
Page	19	Pozzolanic action admixtures
Page	20	Plasticisers for vibro-compression and extrusion
Page	21	Air-entraining and foaming agents
Page	22	Shrinkage reducing admixtures (SRA)
Page	23	Viscosity modifying admixtures
Page	24	Form-release agents
Page	25	Structural and anti-shrinkage fibres
Page	26	Water-repelling agents for concrete with low water absorption and no efflorescence
Page	26	Air-detraining admixture for concrete
Page	26	Admixtures for underwater casting
Page	27	Products for recycling and repair operations for recycling water used for washing and cleaning cement mixers and cement trucks
Page	28	Surface curing compounds

CE marking for admixtures

Since the admixtures for concrete can have extremely different performances and usage, the Standard has different classification categories, different tests and minimum performance levels for every single admixture type.

CLASSIFICATION	DESCRIPTION	TABLE
WR	Water reducing / plasticising admixture	Table 2
HRWR	High range water reducing / super-plasticising admixture	Table 3
WRA	Water retaining admixture	Table 4
AEA	Air entraining admixture	Table 5
SAA	Set accelerating admixture	Table 6
HAA	Hardening accelerating admixture	Table 7
SRA	Set retarding admixture	Table 8
WrA	Water resisting admixture	Table 9
WR + SRA	Set retarding / water reducing / plasticising admixture	Table 10
HRWR + SRA	Set retarding / high range water reducing / super-plasticising admixture	Table 11
WR + SAA	Set accelerating / water reducing / plasticising admixture	Table 12
WMA	Viscosifying / modified viscosity admixture	Table 13

Admixtures that also have important secondary functions can also obtain the certification for two or more categories at the same time. This way the effects of the admixture on concrete, both during the fresh state and hardened, will be able to be studied.

In order to see if the products meet the requirements, the specific tests for each type of admixture must be carried out:

- *when the certificate is first issued;*
- *when a new formula or type of admixture is developed;*
- *when a modification of the formula could significantly influence the admixture's performances;*
- *when a modification of the raw material could significantly influence the admixture's performances.*

The following table lists the classification of **MAPEI** admixtures for concrete, the abbreviations and the Standard table that defines the minimum requirements.

Classification of admixtures for concrete

ADMIXTURES FOR CONCRETE - EN 943-2:2009		
ADMIXTURES	CLASSIFICATION	TABLE
CHRONOS VF 202	HRWR + SRA	11
CHRONOS VF 204	HRWR + SRA	11
CHRONOS VF 210	HRWR + SRA	11
DYNAMON BT 2	HRWR + SRA	11
DYNAMON BT 4	HRWR	3
DYNAMON EASY 11	HRWR	3
DYNAMON EASY 21	HRWR + SRA	11
DYNAMON EASY 31	HRWR + SRA	11
DYNAMON EW	HRWR	3
DYNAMON FLOOR 10	HRWR + SAA	3 + 6
DYNAMON FLOOR 20	HRWR	3
DYNAMON HAA	HAA	7
DYNAMON NRG 1010	HRWR + HAA	3 + 7
DYNAMON NRG 1012	HRWR + HAA	3 + 7
DYNAMON NRG 1014	HRWR + HAA	3 + 7
DYNAMON NRG 1020	HRWR + HAA	3 + 7
DYNAMON NRG 1022	HRWR + HAA	3 + 7
DYNAMON SP1	HRWR + HAA	3 + 7
DYNAMON SR1	HRWR	3
DYNAMON SR2	HRWR + SRA	11
DYNAMON SR3	HRWR + SRA	11
DYNAMON SR4	HRWR + SRA	11
DYNAMON SR21	HRWR	3
DYNAMON SR41	HRWR + SRA	11
DYNAMON SR51	HRWR	3
DYNAMON SR52	HRWR + SRA	11
DYNAMON SR 54	HRWR	3
DYNAMON SR 56	HRWR + SRA	11
DYNAMON SR 58	HRWR	3
DYNAMON SR912	HRWR + SRA	11
DYNAMON SR914	HRWR	3
DYNAMON SR916	HRWR + SRA	11
DYNAMON SX	HRWR	3
DYNAMON SX12	HRWR + SRA + WRA	11 + 4
DYNAMON SX14	HRWR + SRA + WRA	11 + 4
DYNAMON SX22	HRWR + SRA	11
DYNAMON SX24	HRWR	3
DYNAMON SX28	HRWR + HAA	3 + 7
DYNAMON SX32	HRWR + SRA	11

ADMIXTURES FOR CONCRETE - EN 943-2:2009		
ADMIXTURES	CLASSIFICATION	TABLE
DYNAMON SX34	HRWR	3
DYNAMON SX42	HRWR + SRA	11
DYNAMON SX44	HRWR	3
DYNAMON XTEND W 100 N	HRWR	3
DYNAMON XTEND W 100 R	HRWR + SRA	11
DYNAMON XTEND W 200 N	HRWR	3
DYNAMON XTEND W 200 R	HRWR + SRA	11
DYNAMON XTEND W 300 N	HRWR	3
DYNAMON XTEND W 300 R	HRWR + SRA	11
DYNAMON XTEND W 400 N	HRWR	3
DYNAMON XTEND W 400 R	HRWR + SRA	11
DYNAMON XTEND W 500 N	HRWR	3
DYNAMON XTEND W 500 R	HRWR + SRA	11
IDROCRETE DM	WrA	9
IDROCRETE S	WrA	9
MAPEAIR AE 1	AEA	5
MAPEAIR AE 2	AEA	5
MAPEAIR AE 10	AEA	5
MAPEAIR AE 20	AEA	5
MAPEFAST C (formerly Antifreeze liquid)	HAA	7
MAPEFAST CF/L (formerly Antifreeze S liquid)	HAA	7
MAPEFAST CF/P (formerly Antifreeze S powder)	HAA	7
MAPEFLUID N100	HRWR + SRA	11
MAPEFLUID N200	HRWR	3
MAPEFLUID PZ500	HRWR + WrA	3 + 9
MAPEFLUID PZ504	HRWR + SRA + WrA	11 + 9
MAPEFLUID R104	HRWR + SRA	11
MAPEPLAST N10	WR	2
MAPETARD	SRA	8
MAPETARD SD2000	SRA	8
VIBROMIX C1	WR + HAA	2 + 7
VIBROMIX L1	WR	2
VIBROMIX S	WrA	9
VISCOFLUID SCC/10	VMA	13
VISCOSTAR 3K	VMA	13

ADMIXTURES FOR CONCRETE - EN 943-4:2009		
ADMIXTURE	CLASSIFICATION	TABLE
CABLEJET		1
EXPANFLUID		1

Dynamon XTend W superplasticising admixtures with long maintenance of workability

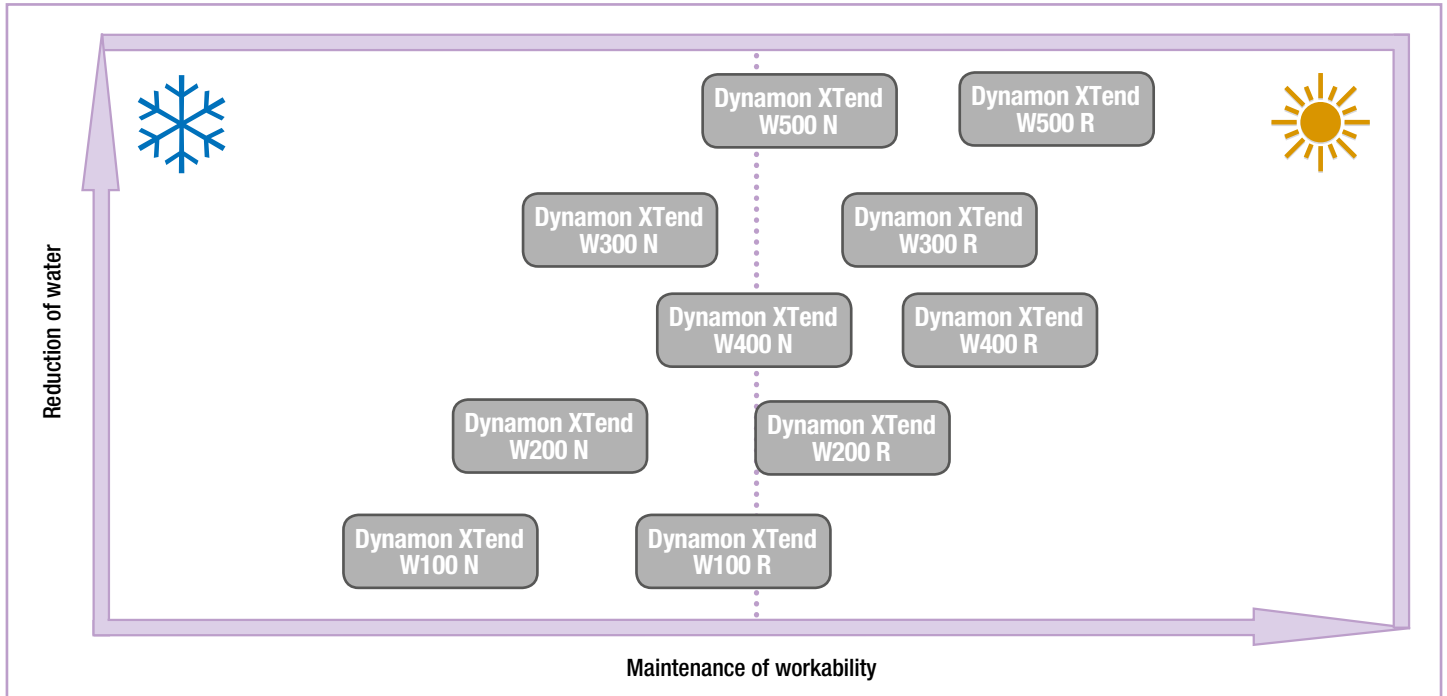

Dynamon XTend W is the new line of super-plasticising admixtures for concrete developed in the MAPEI research centre. Their aim is to provide a concrete solution to all the requirements and problems connected to the production of ready-mixed concrete, with an acrylic base.

(The new admixtures from the **Dynamon XTend W** range join the existing admixtures **Dynamon SR** and **Dynamon SX** to offer a wider, more complete range of products in the ready-mix concrete market).

The high versatility of **Dynamon XTend W100** and **Dynamon XTend 200** makes them particularly suitable for use in normal production cycles for any type of concrete mix in cement plants.

PRODUCT / DESCRIPTION	EFFECT ON SETTING TIME	RECOMMENDED DOSAGE	DENSITY (g/cm ³)
Dynamon XTend W100 N Polyhedral super-plasticiser with good water reducing properties	NEUTRAL	0.5-1.5%	1.05 ± 0.02
Dynamon XTend W100 R Polyhedral super-plasticiser with good water reducing properties and good maintenance of workability	RETARDANT	0.5-1.5%	1.05 ± 0.02
Dynamon XTend W200 N Polyhedral super-plasticiser with good water reducing properties	NEUTRAL	0.5-1.5%	1.06 ± 0.02
Dynamon XTend W200 R Polyhedral super-plasticiser with good water reducing properties and good maintenance of workability	RETARDANT	0.5-1.5%	1.07 ± 0.02

Dynamon XTend W superplasticising admixtures with long maintenance of workability

The new technology found in XTend W, together with the products **Dynamon XTend W300**, **Dynamon XTend W400** and **Dynamon XTend W500**, guarantee that the highest standards of quality can be reached in the production of both normal concrete and, above all, during large site operations, where high performance characteristics are increasingly in demand. The name of each **Dynamon XTend** super-plasticiser is followed by a letter to define its performance level as a set retarder against setting time: N (neutral) or R (retardant).

PRODUCT / DESCRIPTION	EFFECT ON SETTING TIME	RECOMMENDED DOSAGE	DENSITY (g/cm ³)
Dynamon XTend W300 N High-efficiency super-plasticiser for all concrete mixes	NEUTRAL	0.5-1.5%	1.07 ± 0.02
Dynamon XTend W300 R High-efficiency super-plasticiser for all concrete mixes with extended maintenance of workability	RETARDANT	0.5-1.5%	1.10 ± 0.03
Dynamon XTend W400 N High-efficiency super-plasticiser for all concrete mixes	NEUTRAL	0.5-1.5%	1.08 ± 0.02
Dynamon XTend W400 R High-efficiency super-plasticiser for all concrete mixes with extended maintenance of workability	RETARDANT	0.5-1.5%	1.06 ± 0.02
Dynamon XTend W500 N High-efficiency super-plasticiser for all concrete mixes	NEUTRAL	0.5-1.5%	1.11 ± 0.03
Dynamon XTend W500 R High-efficiency super-plasticiser for all concrete mixes with extended maintenance of workability	RETARDANT	0.5-1.5%	1.08 ± 0.02

Dynamon XTend W superplasticising admixtures with long maintenance of workability

The maintenance of workability guaranteed by the **Dynamon XTend W** range may be further improved, where required, by combining the super-plasticiser with **Dynamon EW**, a product used to extend workability.

PRODUCT / DESCRIPTION	EFFECT ON SETTING TIME	RECOMMENDED DOSAGE	DENSITY (g/cm ³)
Dynamon EW Super-plasticiser, workability extender	NEUTRAL	0.2-2%	1.04 ± 0.02

Dynamon EW may be also used in combination with other super-plasticisers from the MAPEI range, as long as they are acrylic-based. By varying the amount of **Dynamon EW** used, the extension of concrete's workability may be modulated without influencing its initial plasticity and the development of its strength after short curing cycles.

The graph shows an example of the maintenance of workability for conventional concrete admixed with **Dynamon XTend W** (ref.mix) and the same concrete admixed with **Dynamon EW** (ref. mix + **Dynamon EW**)

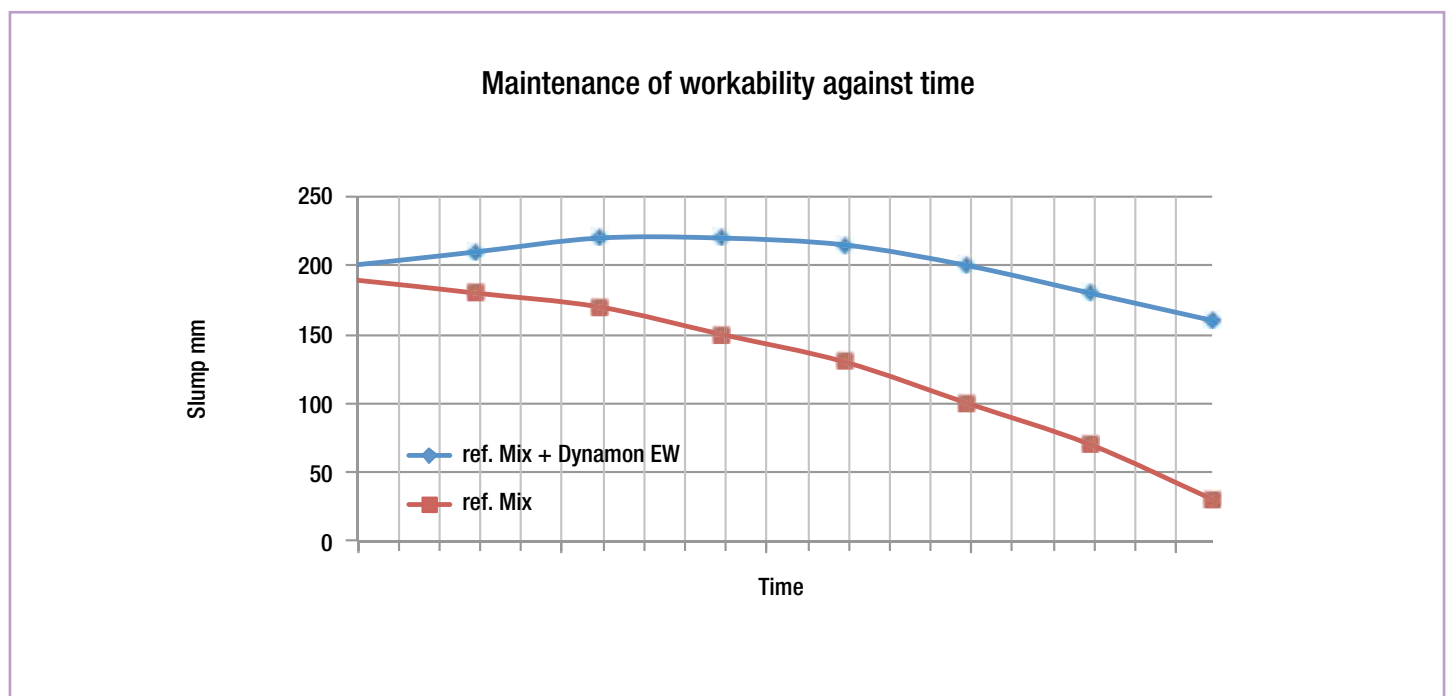

Chronos super-plasticisers

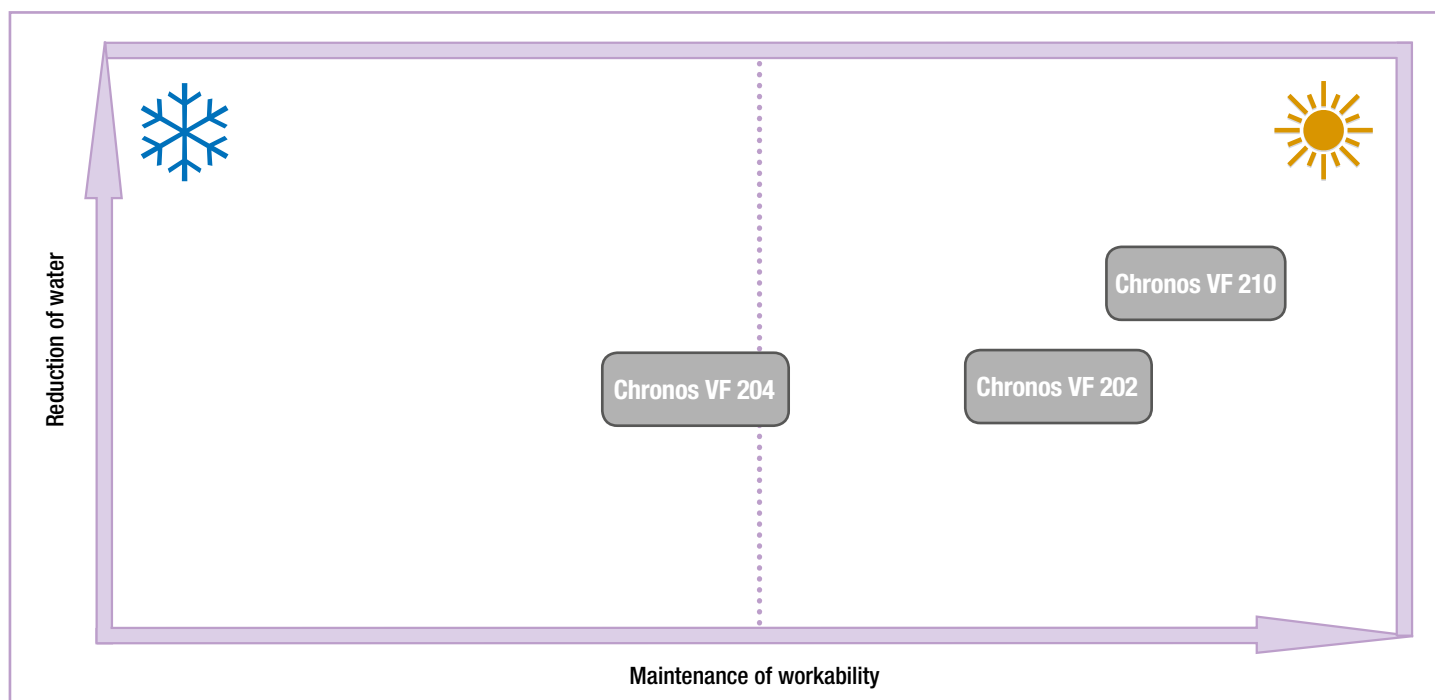

Chronos is the range of MAPEI super-plasticisers made from special polymers, specifically developed for the high quality ready-mixed concrete market.

Chronos super-plasticisers are the ideal solution to guarantee extended workability for concrete when transport times are high due to long distances or if the surrounding conditions reduce the workability time of concrete.

Chronos technology allows the extended workability of concrete to be maintained without resorting to the use of a conventional set retarding admixture, which means the development of strength in the concrete is not delayed, a common occurrence when set retardants are used.

PRODUCT / DESCRIPTION	EFFECT ON SETTING TIME	RECOMMENDED DOSAGE	DENSITY (g/cm ³)
Chronos VF 202 Super-plasticiser to extend workability in hot weather (up to 2 hours) without the use of a setting retardant	RETARDANT	0.6-1.2%	1.11 ± 0.03
Chronos VF 204 Super-plasticiser to extend workability (> 1 hour) without the use of a setting retardant	RETARDANT	0.6-1.2%	1.06 ± 0.02
Chronos VF 210 Super-plasticiser to extend workability (up to 3 hours) without the use of a setting retardant	RETARDANT	0.6-1.2%	1.09 ± 0.02

High-performance super-plasticisers for ready-mixed concrete

Dynamon SR admixtures

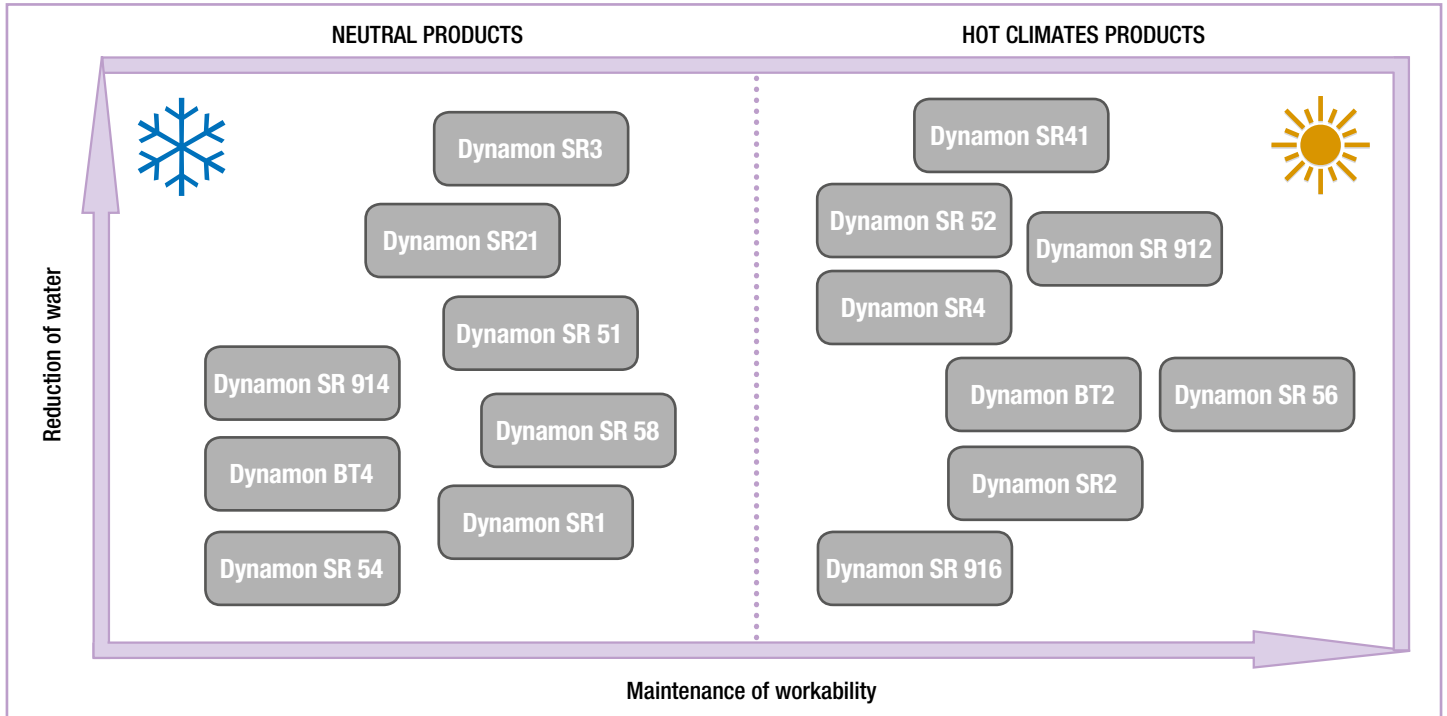

The acrylic super-plasticisers from the **Dynamon SR** range were developed to meet the demand for considerable water reduction combined with extended maintenance of the workability of concrete mixes. The **Dynamon SR** line of admixtures has been enhanced over the years with the introduction of new variations to provide the widest range of products possible, to meet all requirements connected to the production of ready-mixed concrete.

The high performance characteristics of the admixtures from the **Dynamon SR** line make them the ideal range of products for large site work and for work on infrastructures where the highest standards of quality must be met.

The special formulations used to produce **Dynamon SR** admixtures, combined with their excellent maintenance of workability and high water reducing capacity, also make them particularly suitable for use in the production of self-compacting concrete, guaranteeing excellent slump of the mix in spite of its high fines content.

PRODUCT / DESCRIPTION	EFFECT ON SETTING TIME	RECOMMENDED DOSAGE	DENSITY (g/cm ³)
Dynamon SR1 Neutral super-plasticiser for low water/cement ratios with good maintenance of workability	NEUTRAL	0.8-1.5%	1.06 ± 0.02
Dynamon SR2 Super-plasticising retardant with excellent maintenance of workability	RETARDANT	0.8-1.5%	1.09 ± 0.02
Dynamon SR3 Super-plasticiser for low water/cement ratios with excellent maintenance of workability	NEUTRAL	0.5-1.0%	1.08 ± 0.02
Dynamon SR4 Super-plasticising retardant for low water/cement ratios with excellent maintenance of workability	RETARDANT	0.8-1.5%	1.10 ± 0.03

High-performance super-plasticisers for ready-mixed concrete

Dynamon SR admixtures

PRODUCT / DESCRIPTION	EFFECT ON SETTING TIME	RECOMMENDED DOSAGE	DENSITY (g/cm ³)
Dynamon SR21 Super-plasticiser for low water/cement ratios with good maintenance of workability	NEUTRAL	0.7-1.5%	1.08 ± 0.02
Dynamon SR41 Super-plasticising retardant for low water/cement ratios with excellent maintenance of workability	RETARDANT	0.7-1.5%	1.08 ± 0.02
Dynamon SR 51 Super-plasticiser for low water/cement ratios with good maintenance of workability	NEUTRAL	0.7-1.5%	1.07 ± 0.02
Dynamon SR 52 Super-plasticising retardant for low water/cement ratios with excellent maintenance of workability	RETARDANT	0.7-1.5%	1.07 ± 0.02
Dynamon SR 54 Super-plasticiser for very low water/cement ratios with good maintenance of workability	NEUTRAL	0.5-1.5%	1.07 ± 0.02
Dynamon SR 56 Super-plasticising retardant for low water/cement ratios with excellent maintenance of workability	RETARDANT	0.5-1.5%	1.08 ± 0.02
Dynamon SR 58 Neutral super-plasticiser for low water/cement ratios with good maintenance of workability	NEUTRAL	0.5-1.5%	1.06 ± 0.02
Dynamon SR 912 Super-plasticising retardant for low water/cement ratios with excellent maintenance of workability	RETARDANT	0.5-1.5%	1.07 ± 0.02
Dynamon SR 914 Super-plasticiser for low water/cement ratios and good maintenance of workability	NEUTRAL	0.5-1.5%	1.05 ± 0.02
Dynamon SR 916 Super-plasticiser for low water/cement ratios and excellent maintenance of workability	RETARDANT	0.5-1.5%	1.09 ± 0.02

The super-plasticisers **Dynamon BT2** and **Dynamon BT4** are highly specialised members of the **Dynamon SR** family of admixtures and were specifically developed to overcome problems encountered on site due to the use of natural pozzolan-based cement mixes and blast-furnace or pozzolanic cement.

PRODUCT / DESCRIPTION	EFFECT ON SETTING TIME	RECOMMENDED DOSAGE	DENSITY (g/cm ³)
Dynamon BT2 Super-plasticising retardant for concrete with little loss in workability	RETARDANT	0.5-1.0%	1.08 ± 0.02
Dynamon BT4 Super-plasticiser for ready-mixed concrete	NEUTRAL	0.5-1.0%	1.06 ± 0.02

High-performance super-plasticisers for ready-mixed concrete

Dynamon SR admixtures

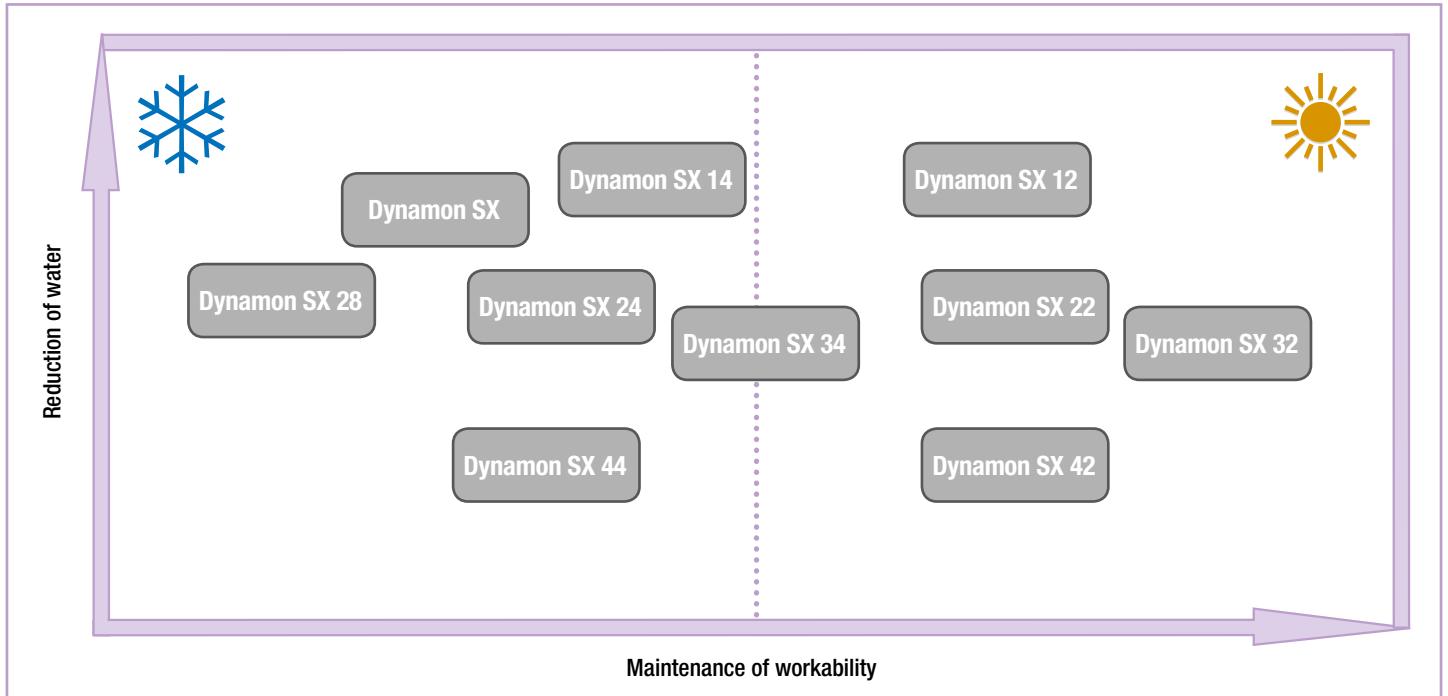

The **Dynamon SX** line of admixtures has been developed specifically for the production of ready-mixed concrete. The wide range of super-plasticisers from the **Dynamon SX** line allows you to choose the right admixture for your specific requirements. All the products in the range are characterised by good water reducing properties and good compatibility with all types of cement normally available on the market. The **Dynamon SX** range includes both neutral admixtures, which means they are suitable for use all year round, and admixtures aimed at extending workability, more suitable, therefore, for use in the summer and in hot climates.

PRODUCT / DESCRIPTION	EFFECT ON SETTING TIME	RECOMMENDED DOSAGE	DENSITY (g/cm ³)
Dynamon SX Super-plasticiser for low water/cement ratios with good maintenance of workability	NEUTRAL	0.5-2.0%	1.07 ± 0.02
Dynamon SX 12 Super-plasticising retardant for low water/cement ratios with excellent maintenance of workability	RETARDANT	0.5-1.5%	1.07 ± 0.02
Dynamon SX 14 Super-plasticiser for low water/cement ratios with good maintenance of workability; integrator for fines	RETARDANT	0.5-1.5%	1.06 ± 0.02

High-performance super-plasticisers for ready-mixed concrete

Dynamon SR admixtures

PRODUCT / DESCRIPTION	EFFECT ON SETTING TIME	RECOMMENDED DOSAGE	DENSITY (g/cm ³)
Dynamon SX 22 Super-plasticising retardant for low water/cement ratios with excellent maintenance of workability	RETARDANT	0.5-1.5%	1.09 ± 0.02
Dynamon SX 24 Super-plasticiser for low water/cement ratios with good maintenance of workability	NEUTRAL	0.5-1.5%	1.07 ± 0.02
Dynamon SX 28 Super-plasticising accelerator for ready-mixed concrete with a high reduction of mixing water	ACCELERATOR	0.5-1.5%	1.11 ± 0.03
Dynamon SX 32 Super-plasticising retardant for low water/cement ratios with excellent maintenance of workability	RETARDANT	0.5-1.5%	1.08 ± 0.02
Dynamon SX 34 Neutral super-plasticiser for low water/cement ratios with good maintenance of workability. Integrator for fines.	NEUTRAL	0.5-1.5%	1.07 ± 0.02
Dynamon SX 42 Super-plasticising retardant for low water/cement ratios with excellent maintenance of workability	RETARDANT	0.5-1.5%	1.08 ± 0.02
Dynamon SX 44 Neutral super-plasticiser for low water/cement ratios with good maintenance of workability	NEUTRAL	0.5-1.5%	1.06 ± 0.02

Multi-purpose super-plasticisers for ready-mixed concrete

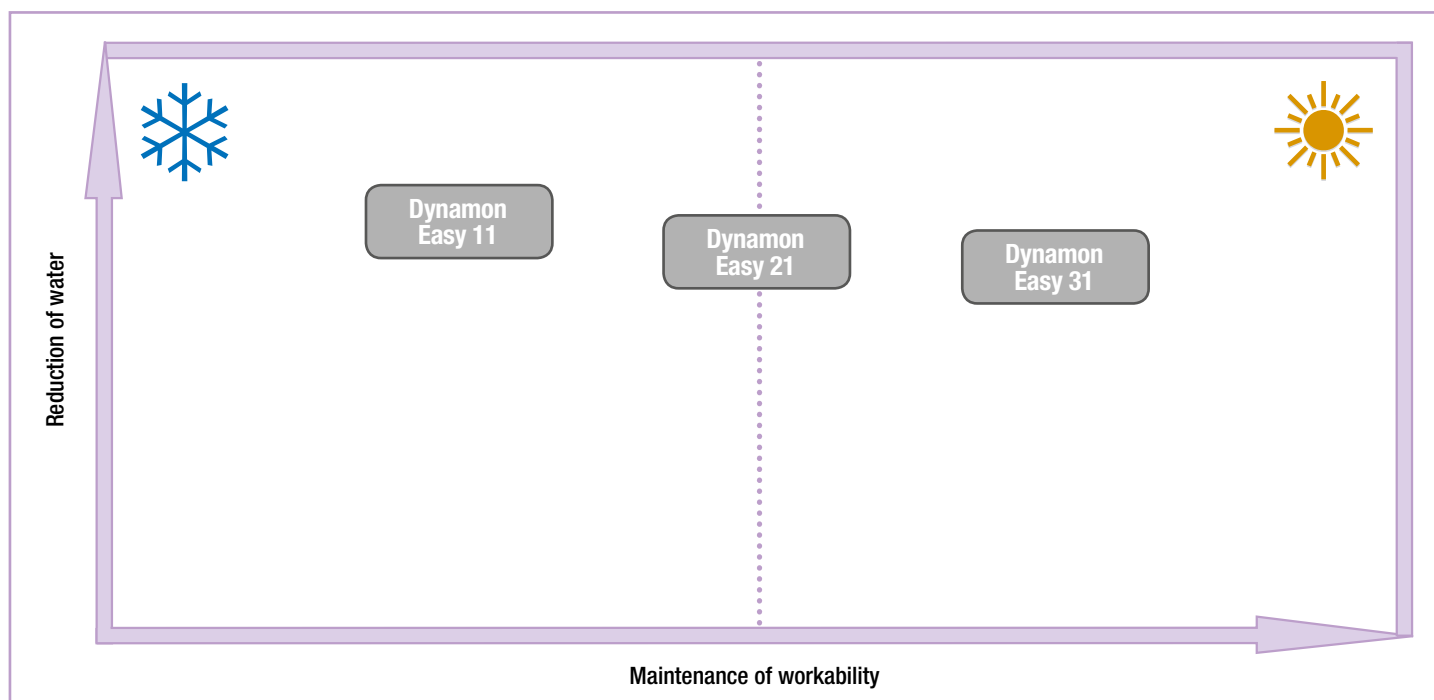

This range of multi-purpose super-plasticisers is characterised by admixtures which are different to each other mainly for the amount of time they maintain workability at various temperatures, for an ideal solution in all seasons. In the range of specific super-plasticising admixtures for the ready-mixed concrete market, MAPEI presents a family of products specifically developed and formulated to meet the everyday requirements of concrete plants.

PRODUCT / DESCRIPTION	EFFECT ON SETTING TIME	RECOMMENDED DOSAGE	DENSITY (g/cm ³)
Dynamon Easy 11 Multi-purpose super-plasticiser for low water/cement ratios	NEUTRAL	0.5-2.0%	1.04 ± 0.02
Dynamon Easy 21 Multi-purpose super-plasticising retardant for low water/cement ratios with good maintenance of workability	RETARDANT	0.5-2.0%	1.08 ± 0.02
Dynamon Easy 31 Multi-purpose super-plasticising retardant for low water/cement ratios with excellent maintenance of workability	RETARDANT	0.5-2.0%	1.10 ± 0.03

Conventional plasticisers and super-plasticisers for ready-mixed concrete

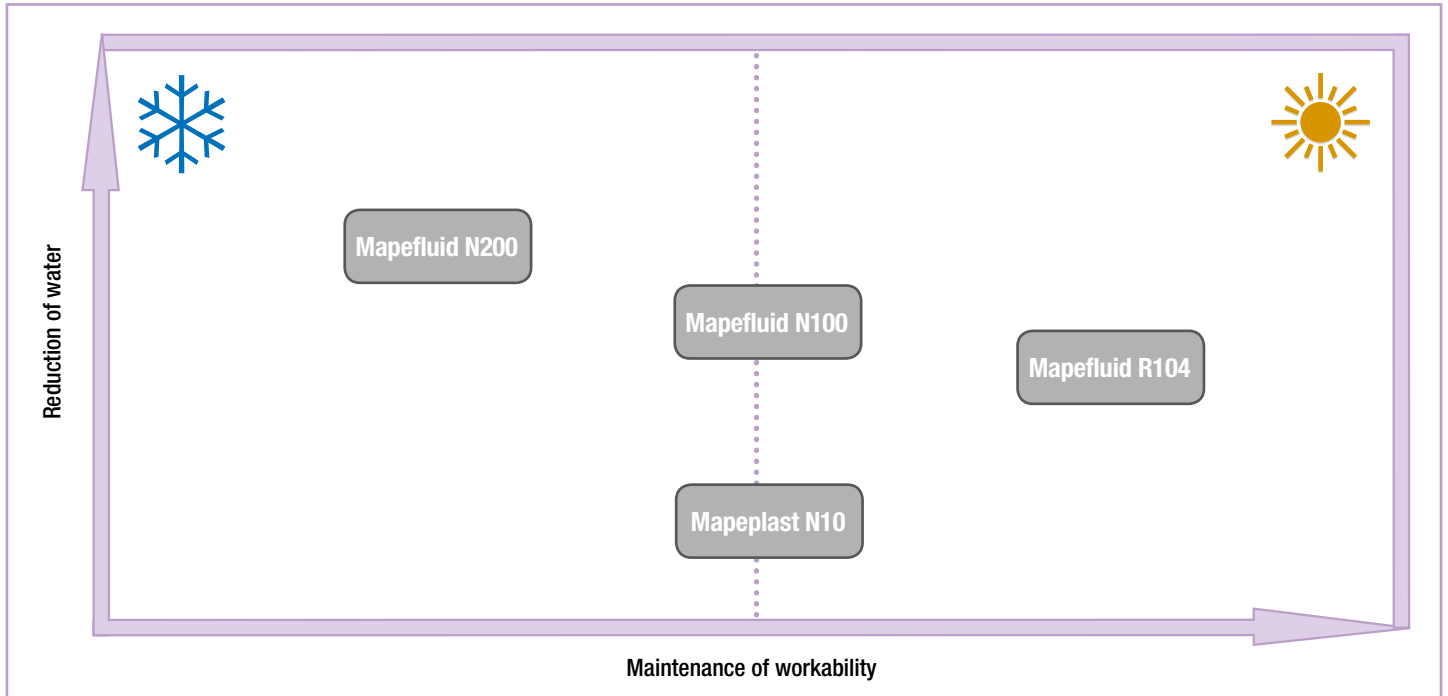

This range of naphthalene sulfonate and lignosulfonate based plasticisers and super-plasticisers, characterised by their flexible dosage rates, are aimed mainly at the ready-mixed concrete market.

The products in this range are suitable for a wide range of applications and combine good reduction in water/cement ratios, good maintenance of workability and in general, an excellent compatibility with the main types of concrete available on the market.

PRODUCT / DESCRIPTION	EFFECT ON SETTING TIME	RECOMMENDED DOSAGE	DENSITY (g/cm ³)
Mapeplast N10 Plasticiser with good maintenance of workability	NEUTRAL	0.2-0.5%	1.20 ± 0.03

PRODUCT / DESCRIPTION	EFFECT ON SETTING TIME	RECOMMENDED DOSAGE	DENSITY (g/cm ³)
Mapefluid N200 Naphthalene-based neutral super-plasticiser for concrete	NEUTRAL	0.5-1.5%	1.20 ± 0.03
Mapefluid N100 Super-plasticiser for ready-mixed concrete with good maintenance of workability	RETARDANT	0.5-1.5%	1.17 ± 0.03
Mapefluid R104 Naphthalene-based super-plasticising retardant with good maintenance of workability	RETARDANT	0.8-2.1%	1.18 ± 0.03

High-performance super-plasticisers for precast concrete elements

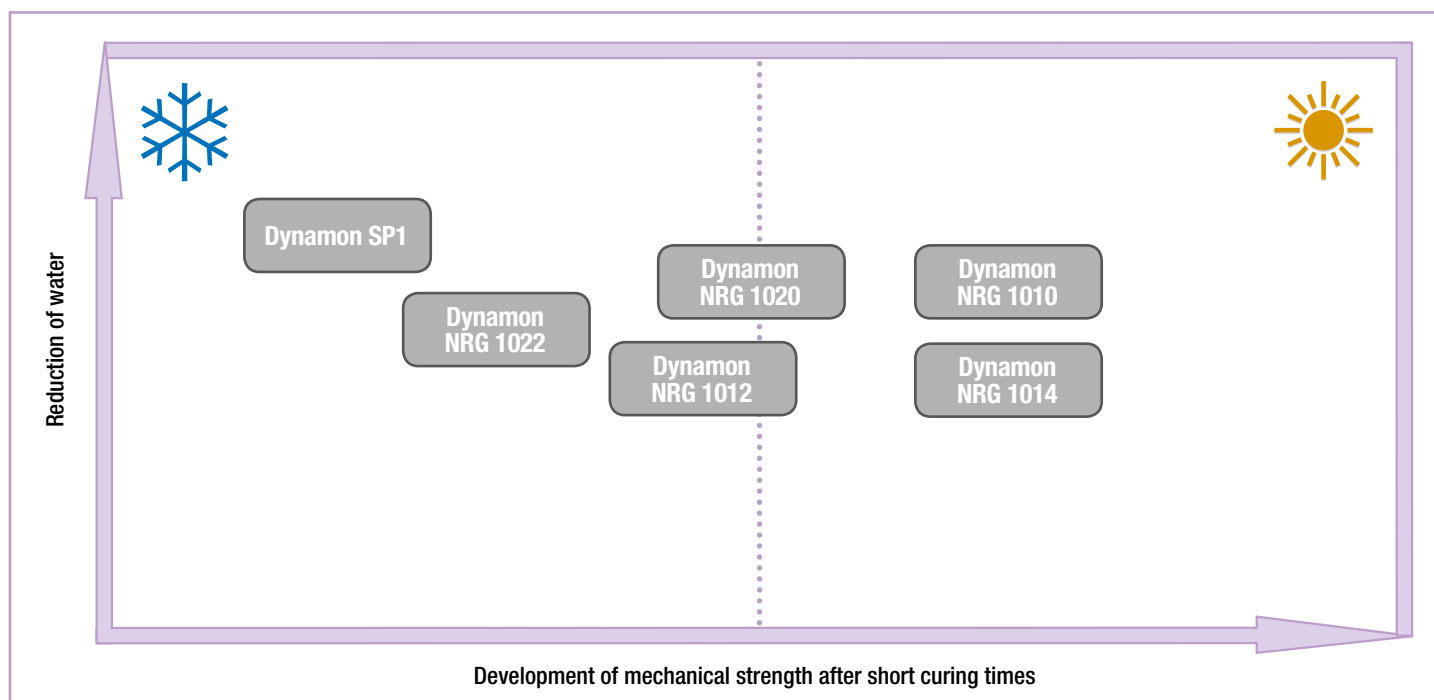

To solve the problems encountered when making large precast elements and to offer a significant contribution to the innovation and development of the sector, MAPEI has developed the **Dynamon NRG** range. The super-plasticisers in this range are calibrated to progressively and completely eliminate steam curing of cast concrete and, as a result, increase the durability and service life of reinforced concrete structures.

The performance achieved when using these super-plasticisers makes them particularly useful when mixing S.C.C., in that they guarantee high slump of the mix without the negative effects of excessive stickiness in the cementitious matrix.

PRODUCT / DESCRIPTION	EFFECT ON HARDENING TIME	RECOMMENDED DOSAGE	DENSITY (g/cm ³)
Dynamon NRG 1010 Super-plasticising accelerator for extremely quick demoulding operations (6-8 hours) without steam curing	ACCELERATOR	0.5-1.5%	1.05 ± 0.02
Dynamon NRG 1012 Super-plasticising accelerator for quick demoulding operations (16-18 hours) without steam curing	ACCELERATOR	0.5-1.5%	1.06 ± 0.02
Dynamon NRG 1014 Super-plasticising accelerator operations (16-18 hours) without steam curing and viscous agent for SCC	ACCELERATOR	0.5-1.5%	1.05 ± 0.02
Dynamon NRG 1020 Ultra high-efficiency super-plasticising accelerator for extremely quick moulding operations (6-8 hours) without steam curing	ACCELERATOR	0.5-1.5%	1.07 ± 0.02
Dynamon NRG 1022 Super-plasticising with excellent maintenance of workability and quick demoulding without steam curing	ACCELERATOR	0.5-1.5%	1.06 ± 0.02
Dynamon SP1 Super-plasticiser for very low water/cement ratios with good maintenance of workability; also suitable for steam curing	ACCELERATOR	0.6-1.2%	1.09 ± 0.02

Super-plasticisers for industrial floors



Dynamon Floor is a range of MAPEI super-plasticisers, specifically developed as a solution to all those problems encountered when casting and finishing off concrete industrial floors.

The products in the **Dynamon Floor** range have been developed to optimise the workability time of concrete and finishing operations on site in a variety of operating conditions and at different temperatures.

Apart from being used in concrete for normal flooring, the products in the **Dynamon Floor** range are also a component of the **Mapecrete System** for industrial flooring without expansion joints, and may be used in combination with the products from the **Mapecfibre** range to make fibre-reinforced concrete.

PRODUCT / DESCRIPTION	EFFECT ON SETTING TIME	RECOMMENDED DOSAGE	DENSITY (g/cm ³)
Dynamon Floor 10 High-efficiency, super-plasticising setting accelerator for internal and external floors at low temperatures	ACCELERATOR	0.8-2.0%	1.28 ± 0.03
Dynamon Floor 20 Super-plasticising setting accelerator for internal and external floors in hot weather	NEUTRAL	0.8-2.0%	1.10 ± 0.03

Setting and hardening retardants

Mapetard is the range of MAPEI admixtures developed and designed to regulate setting and hardening times of concrete mixes. The various chemical combinations used to manufacture them means that the right solution is always available, even in the harshest climatic conditions and in concrete mixes made from the widest range of materials.

The products from the **Mapetard** line allow the most torrid climates to be compensated for by delaying setting times and extending workability, thereby allowing concrete to be poured in more favourable conditions.

Admixtures from the **Mapetard** line are also widely used in large structures constructed over extended shifts to maintain the concrete's plasticity and prevent the formation of surfaces with gaps or steps. The possibility of controlling setting times makes them particularly suitable in the production of Roller Compacted Concrete and especially in the construction of dams to contain the development of hydration heat and lower the risk of the formation of cold joints in the concrete.

Because the surrounding temperature, the type and amount of cement used and the water-cement ratio all have considerable influence on the setting time of concrete, it is not possible to accurately quantify the amount of admixture required to achieve a certain setting time.

The following graphs, however, may be used to calculate approximate setting times according to the surrounding temperature and the amount of **Mapetard** used.

Since the graphs are only to be used as a general guide, we recommend that testing is always carried out on concrete admixed with **Mapetard** in the same conditions it is to be used to verify its performance characteristics.

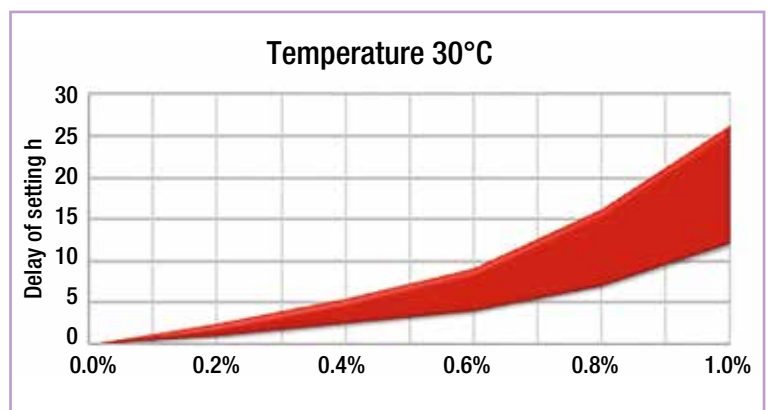
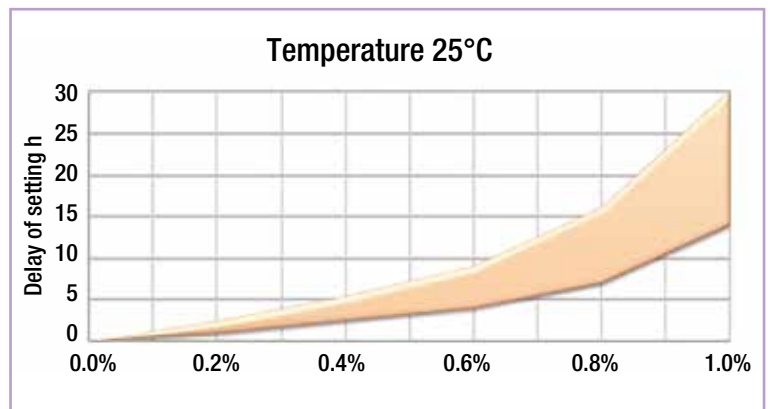
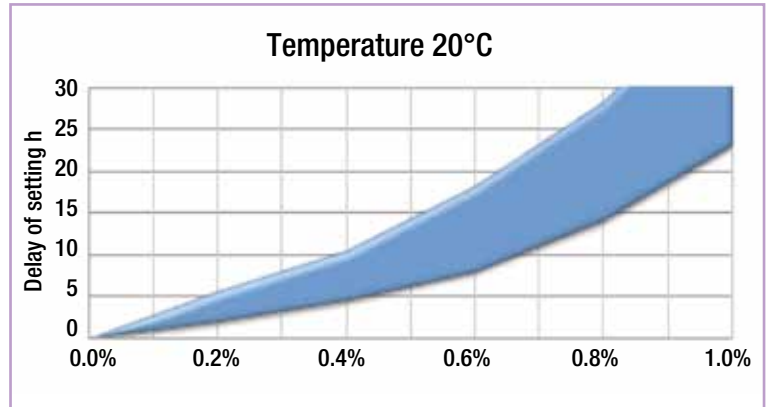

PRODUCT / DESCRIPTION	EFFECT ON SETTING TIME	RECOMMENDED DOSAGE	DENSITY (g/cm ³)
Mapetard Retardant with a slight plasticising effect	RETARDANT	0.2-0.5%	1.08 ± 0.02
Mapetard SD2000 High efficiency retardant	RETARDANT	0.1-2.0%	1.11 ± 0.03

Setting and hardening admixtures

MAPEI proposes a complete range of setting and hardening accelerating admixtures for concrete.

The products in this range have been specifically developed to make the stripping of formwork from precast structures easier and to prevent the water used to mix for fresh concrete cast in particularly cold climates from freezing.

The various products in this range means that the most suitable solution may be chosen for both reinforced and unreinforced concrete (CHLORIDE-FREE products).

PRODUCT	DOSAGE	A/C	COMPRESSIVE STRENGTH 20°C		SETTING TIME 20°C
			24 h	7 g	
Reference	–	0.5	100%	100%	100%
Dynamon HAA	3%		130%	105%	85%
Mapefast CF/L	1.5%		115%	110%	90%
Mapefast C	3%		135%	95%	80%

PRODUCT	DOSAGE	A/C	COMPRESSIVE STRENGTH 5°C		SETTING TIME 5°C
			48 h	7 g	
Reference	–	0.5	100%	100%	100%
Dynamon HAA	3%		155%	130%	60%
Mapefast CF/L	1.5%		135%	125%	80%
Mapefast C	3%		165%	140%	55%

PRODUCT / DESCRIPTION	MAIN APPLICATION	RECOMMENDED DOSAGE	DENSITY (g/cm ³)
Dynamon HAA Chloride-free hardening accelerator to increase mechanical strength during stripping operations	Precast - Site use	1.0-3.0%	1.30 ± 0.03
Mapefast CF/L (formerly Antifreeze S liquid) Chloride-free liquid hardening accelerator to make concrete at low temperatures	Ready Mix - Site use	0.75-1.5%	1.30 ± 0.03
Mapefast CF/P (formerly Antifreeze S powder) Chloride-free powdered hardening accelerator to make concrete at low temperatures	Ready Mix - Site use	1.0-2.0%	
Mapefast C (formerly Antifreeze) Setting accelerator with chlorides for unreinforced concrete and mortar	Ready Mix - Site use	1.0-3.0%	1.35 ± 0.03

Pozzolanic action admixtures

PRODUCT	INCREASE IN DURABILITY OF CONCRETE	REDUCTION OF HYDRATION HEAT	REDUCTION OF WATER	INCREASE IN MECHANICAL STRENGTH	REDUCTION IN PERMEABILITY	INCREASE IN WORKABILITY TIME	REDUCTION OF BLEEDING
Mapeplast SF	☐	-	-	☐	☐	-	☐
Mapeplast PZ 300	☐	☐	-	☐	☐	-	☐
Mapefluid PZ500	☐	-	☐	☐	☐	-	☐
Mapefluid PZ504	☐	-	☐	☐	☐	☐	☐

Admixtures with a high level of pozzolanic activity are powdered admixtures used to make special concrete that requires a more cohesive mix, a reduction in surface bleeding, improved mechanical properties and a reduction in permeability.

PRODUCT / DESCRIPTION	MAIN APPLICATION	RECOMMENDED DOSAGE
Mapeplast SF Pozzolanic-activity powder component. Made of Silica Fume	Ready Mix - Site use - Precast	5.0-10.0 kg/m ³
Mapefluid PZ500 Pozzolanic-activity neutral super-plasticising powder for high-quality concrete. Made of Silica Fume	Ready Mix - Site use	20-60 kg/m ³
Mapefluid PZ504 Pozzolanic-activity super-plasticising retardant powder for high-quality concrete. Made of Silica Fume	Ready Mix - Site use	20-60 kg/m ³

Pozzolanic action admixtures

Mapeplast PZ300 is a powdered admixture made from pozzolanic-reaction, micronized components specifically developed to reduce the development of hydration heat normally generated in mass pours. The correct formulation of the mix design allows **Mapeplast PZ300** to partially replace the amount of cement used. The aim is to reduce the amount of heat of hydration and prevent cracking due to thermal shrinking, but without affecting the development of strength on a long term basis.

PRODUCT / DESCRIPTION	MAIN APPLICATION	RECOMMENDED DOSAGE
Mapeplast PZ300 Micronized pozzolanic-activity powder admixture	Ready Mix - Site use	50-250 kg/m ³

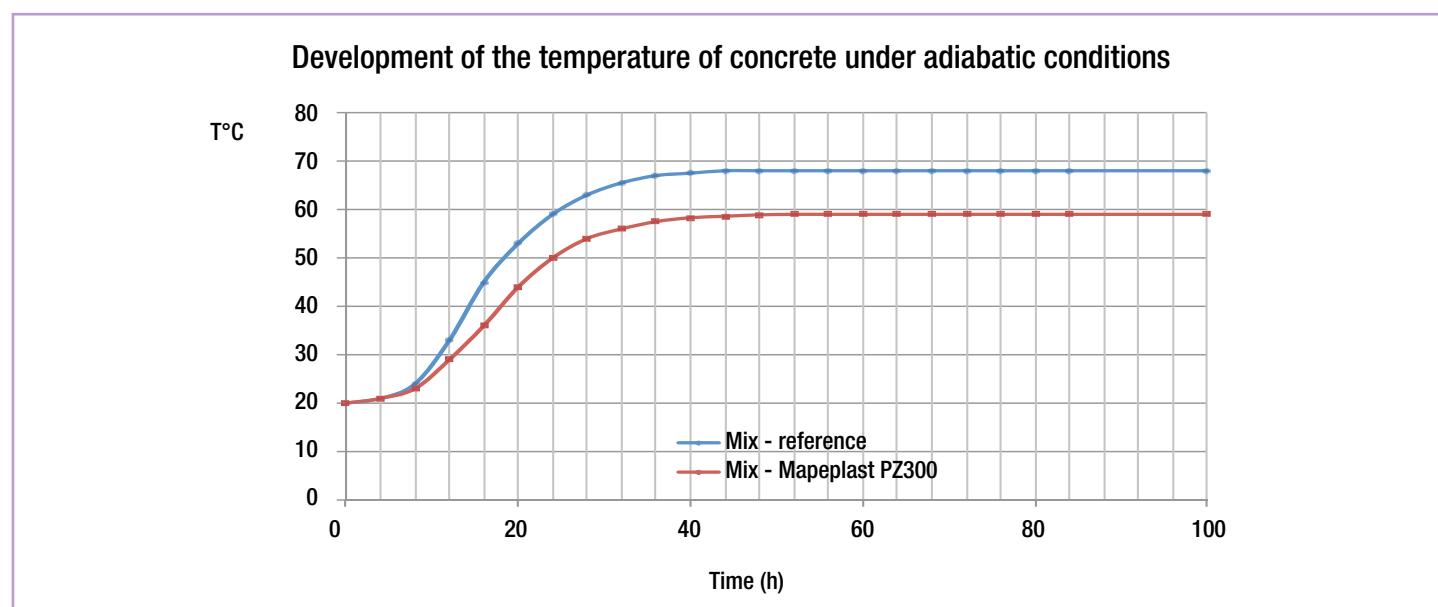

	MIX REF	MIX MAPEPLAST PZ300
SAND	1004	885
5/12	463	531
12/25	379	390
CEMENT	380	320
MAPEPLAST PZ300	–	100
WATER	190	190
SUPER-PLASTICISER	3	3

MECHANICAL STRENGTH		
Rc (28 days)	53	48
Rc (60 days)	55	53
Rc (90 days)	56	56

Plasticisers for vibro-compression and extrusion

Vibromix is MAPEI's range of admixtures specifically developed to solve the problems encountered when making lightweight precast elements. The various products in the **Vibromix** range are specifically formulated according to their final use, and are used to improve the characteristics of various concrete elements.

The **Vibromix** range includes a number of admixtures which increase the plasticity of no-slump consistency mixes, significantly increase the level of hydration of the cement and accelerate the development of strength after short curing cycles, enabling elements to be handled more quickly, the absorption of water to be reduced and progressively and totally eliminate the formation of efflorescence.

PRODUCT / DESCRIPTION	MAIN APPLICATION	RECOMMENDED DOSAGE	DENSITY (g/cm ³)
Vibromix L1 Plasticiser	Lightweight prefabricated elements	0.2-0.8%	1.20 ± 0.03
Vibromix C1 High-quality plasticising hardening accelerator	Lightweight prefabricated elements	0.2-0.8%	1.03 ± 0.02
Vibromix S High-efficiency water-repellent plasticiser for elements with no water absorption and no efflorescence	Lightweight prefabricated elements	0.2-1.2%	1.03 ± 0.02

Air-entraining and foaming agents

The products in the **Mapeair** range are air-entraining and foaming admixtures which make concrete resistant to freeze/thaw cycles or reduce its density.

The products from the **Mapeair** line allow a sufficient quantity of evenly distributed micro air bubbles with a constant size to form in the concrete to guarantee efficient resistance to freeze/thaw cycles.

The air-entraining admixtures in the **Mapeair AE** may be used in combination with retardants from the **Mapetard** range to produce pumped masonry mortar.

The foaming agents from the **Mapeair LA** range have the capacity to hold a high quantity of air in the concrete so that it has very low density, prevents the finer particles from floating to the surface, and makes the pumping of lightweight concrete and/or concrete with a low fine sand content easier, including over long distances.

PRODUCT / DESCRIPTION	MAIN APPLICATION	RECOMMENDED DOSAGE	DENSITY (g/cm ³)
Mapeair AE 1 (formerly Mapeplast PT1) Air-entraining admixture for concrete resistant to freeze/thaw cycles and lightweight mortar	Ready Mix - Site use	0.03-0.3%	1.02 ± 0.02
Mapeair AE 2 (formerly Mapeplast PT2) Air-entraining admixture for concrete resistant to freeze/thaw cycles and lightweight mortar	Ready Mix - Site use	0.02-0.3%	1.02 ± 0.02
Mapeair AE 10 Air-entraining compound for concrete resistant to freeze/thaw cycles	Ready Mix - Site use	0.4-0.8%	1.01 ± 0.02
Mapeair AE 20 Air-entraining compound for concrete resistant to freeze/thaw cycles	Ready Mix - Site use	0.2-0.8%	1.01 ± 0.02
Mapeair LA/L (formerly Mapeplast LA liquid) Foaming agent and pumping aid for concrete and lightweight mortar. Ideal for cellular concrete	Ready Mix - Site use	0.8-1.2 l/m ³	1.14 ± 0.03
Mapeair LA/P (formerly Mapeplast LA powder) Foaming agent and pumping aid for concrete and lightweight mortar. Ideal for fluid filling mixes	Ready Mix - Site use	0.5 kg/m ³	

Shrinkage reducing admixtures (SRA)

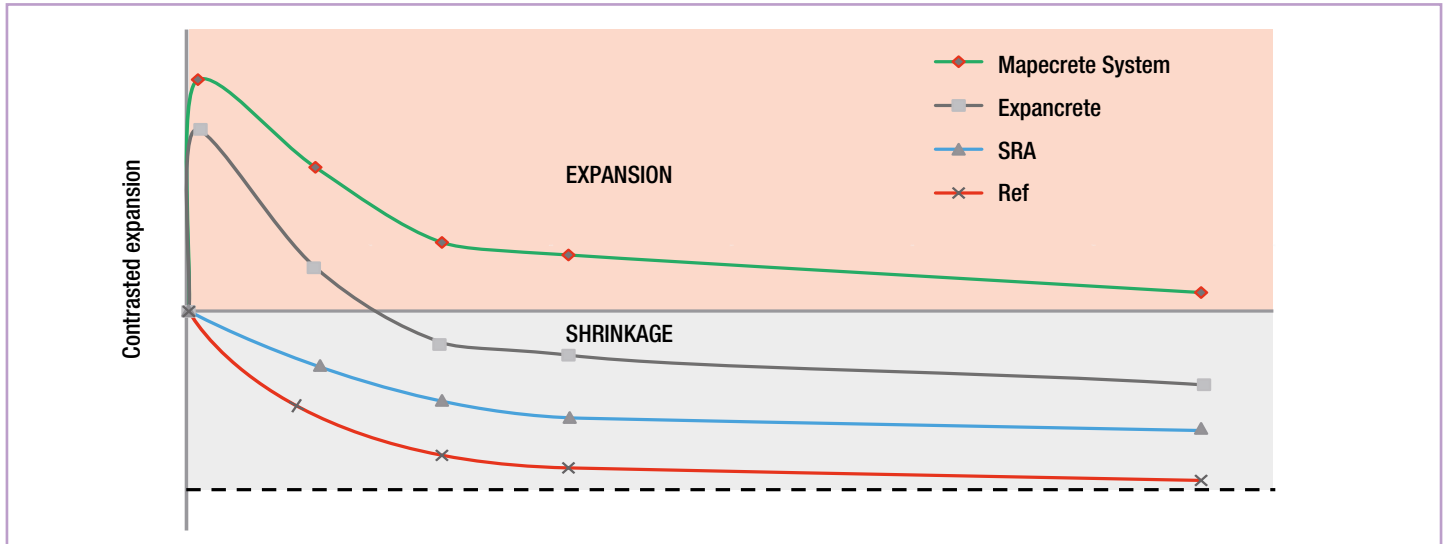

Expancrete and the products from the **Mapecrete SRA** range are, respectively, expanding agents and shrinkage reducing admixtures. The use of these products allows high dimensional stability concrete and mortar to be mixed with no cracking from plastic shrinkage.

Expancrete allows the concrete to expand during the hardening phase which, if contrasted correctly, considerably reduces the build up of stresses caused by hygrometric shrinkage.

The admixtures from the **Mapecrete SRA** range considerably reduce hygrometric shrinkage, whether there is opposing reinforcement or not, by acting mainly at the water-hydration crystals interface of the cement.

Apart from being used in normal concrete, **Expancrete** and **Mapecrete SRA 25** are also as integrators in the **Mapecrete System** to build structures without contraction joints.

PRODUCT / DESCRIPTION	SEASON	RECOMMENDED DOSAGE	DENSITY (g/cm ³)
Expancrete Powdered expansion agent for controlled-shrinkage concrete	ALL YEAR	5.0-8.0%	
Mapecrete SRA Admixture to reduce hydraulic shrinkage and the formation of cracks for compensated-shrinkage mortar and concrete	ALL YEAR	1.0-2.0%	0.91 ± 0.02
Mapecrete SRA 25 Admixture to reduce hydraulic shrinkage and the formation of cracks for compensated-shrinkage concrete and mortar and seamless flooring	ALL YEAR	1.0-2.0%	0.99 ± 0.02

Expanfluid and **Cablejet** are powdered admixtures used to make injectable slurry and are ideal for filling pre-stressed cable housings, anchoring rebar and tie-bars and filling gaps and cracks in concrete and rocks.

PRODUCT / DESCRIPTION	SEASON	RECOMMENDED DOSAGE	DENSITY (g/cm ³)
Expanfluid Powdered expansion agent for injected slurry	ALL YEAR	3.0-6.0%	
Cablejet Plasticizing and expanding agent for preparing shrinkage-free, highly-fluid pumpable slurries for injection	ALL YEAR	2-4%	

Viscosity modifying admixtures

The viscosifying agents from the MAPEI range are specifically formulated to facilitate the pumping of concrete with a low fine particles content or with crushed aggregates, and to improve the rheological properties of S.C.C. These products are particularly recommended to facilitate the pumping of normal concrete with a low fine sand content, with coarse sand and/or with a low cement content, including over long distances. The use of MAPEI viscosifying agents for the production of S.C.C. improves the rheological properties of the mix, considerably reduces bleeding and segregation and allows the amount of mineral fillers such as limestone and fly-ash to be reduced.

PRODUCT / DESCRIPTION	APPLICATION	RECOMMENDED DOSAGE	DENSITY (g/cm ³)
Viscofluid SCC/10 Viscosising admixture for the production of self-compacting concrete (SCC)	Ready Mix - Precast	1.0-2.0%	1.02 ± 0.02
Viscostar 3K Multi-purpose viscosising admixture for the production of self-compacting concrete without filler material	Ready Mix - Precast	0.3-2.5 l/m ³	1.01 ± 0.02

Form-release agents

PROPERTIES	MAPEFORM ECO 31	MAPEFORM ECO OIL	MAPEFORM 1200	MAPEFORM 1500	DMA 1000	DMA 2000
Horizontal metal formwork	☞☞☞☞☞	☞☞☞☞☞	☞☞☞☞☞	☞☞☞☞☞	–	☞☞☞☞☞
Vertical metal formwork	☞☞☞☞☞	☞☞☞☞	☞☞☞☞☞	☞☞☞☞	–	☞☞☞☞
Traditional wooden formwork	–	–	–	–	☞☞☞☞☞	–
Non-absorbent wooden formwork	☞	☞☞☞	☞☞☞☞	☞☞☞	☞☞☞☞	☞☞☞
Plastic formwork	☞☞☞☞	☞☞☞☞	☞☞☞☞	☞☞☞☞	☞☞	☞☞☞
Corrosion inhibitor for metal formwork	☞☞☞☞	☞☞☞☞	☞☞☞	☞☞☞☞	–	☞☞☞☞☞
Exposed surface	☞☞☞☞	☞☞☞☞☞	☞☞☞	☞☞☞	☞☞☞	☞☞☞☞
Resistance to steam curing cycles	☞☞☞☞	☞☞☞☞☞	☞☞	☞☞☞☞	–	☞☞☞☞☞

All MAPEI from-release compounds have been designed and developed to offer a solution to problems normally encountered when stripping concrete in pre-fabricated concrete plants and on site. Selecting the most suitable product and applying the product correctly gives you the best results in terms of the finish of the elements and protection for the formwork.

The ecological products from the **Mapeform Eco** range give the best finish when horizontal and vertical formwork are used, combined with an optimum yield of the form-release agent.

Form Release Agent DMA 1000 guarantees excellent yield on all types of formwork (planks, panels, etc.), combined with its ease of use under all site conditions.

PRODUCT / DESCRIPTION	SEASON	YIELD	DENSITY (g/cm ³)
Mapeform Eco 31 Chemical-action vegetable oil-based form-release agent in water emulsion to improve exposed surfaces	ALL YEAR	15-25 g/m ²	0.96 ± 0.01
Mapeform Eco Oil Multi-purpose vegetable oil-based stripping agent in water emulsion for metal and plastic formwork. Suitable for steam curing	ALL YEAR	10-25 g/m ²	0.91 ± 0.01
Mapeform 1200 Form-release agent for rapid delivery	ALL YEAR	10-25 g/m ²	0.8 ± 0.01
Mapeform 1500 Multi-purpose low viscosity chemical/physical action form-release solution	ALL YEAR	20-25 g/m ²	0.87 ± 0.01
Form Release Agent DMA 1000 Emulsifiable form-release agent for all types of wooden formwork	ALL YEAR	10-30 g/m ²	0.89 ± 0.01
Form Release Agent DMA 2000 Universal form-release agent with chemical and physical action	ALL YEAR	35-40 g/m ²	0.87 ± 0.01

Structural and anti-shrinkage fibres

Mapefibre CN 54



Mapefibre ST 30



Mapefibre ST 42



Mapefibre NS12 / Mapefibre NS18



The polymer fibres for concrete from the **Mapefibre** range are available in two types: structural and non-structural. The products in this range have been specifically developed to meet all structural strengthening requirements for concrete, and to prevent and contain cracking phenomenon caused by plastic shrinkage in concrete.

Mapefibre ST and **Mapefibre CN** are particularly suitable for the structural strengthening of concrete, in that they may be used to partially or completely substitute secondary steel reinforcement.

Mapefibre NS fibres are dimensioned specifically to prevent and control cracking phenomenon caused by plastic shrinkage in concrete.

PRODUCT / DESCRIPTION	RECOMMENDED DOSAGE
<p>Mapefibre ST 30 30 mm structural polymeric fibres used as a substitute for reinforcement mesh in traditional floors</p>	1-7 kg/m ³
<p>Mapefibre ST 42 42 mm structural polymeric fibres used as a substitute for reinforcement mesh in traditional floors</p>	1-7 kg/m ³
<p>Mapefibre CN 54 54 mm structural polymeric fibres used as a substitute for reinforcement mesh in traditional flooring and shotcrete</p>	1-7 kg/m ³
<p>Mapefibre NS 12 Anti-shrinkage polypropylene fibres to reduce cracking</p>	0.4-0.8 kg/m ³
<p>Mapefibre NS 18 Anti-shrinkage polypropylene fibres to reduce cracking</p>	0.4-0.8 kg/m ³

Water-repelling agents for concrete with low water absorption and no efflorescence

PRODUCT / DESCRIPTION	MAIN APPLICATION	RECOMMENDED DOSAGE	DENSITY (g/cm ³)
Idrocrete DM Water-repellent compound for concrete and mortar which do not absorb water and without efflorescence	Ready Mix - Site use - Precast	0.2-1.0%	1.03 ± 0.02
Idrocrete S Water-repellent compound for concrete and mortar which do not absorb water and without efflorescence	Ready Mix - Site use - Precast	0.2-1.2%	1.03 ± 0.02

Air-detraining admixture for concrete

PRODUCT / DESCRIPTION	MAIN APPLICATION	RECOMMENDED DOSAGE	DENSITY (g/cm ³)
Mapeair Zero Liquid admixture to eliminate excess air in concrete	Ready Mix - Site use - Precast	0.1-1.0%	1.00 ± 0.02

Admixtures for underwater casting

PRODUCT / DESCRIPTION	MAIN APPLICATION	RECOMMENDED DOSAGE
Mapeplast UW Cohesive admixture for anti-leaching underwater casts	UNDERWATER	5-10 kg/m ³

Products for recycling and repair operations

for recycling water used for washing and cleaning cement mixers and cement trucks

PRODUCT / DESCRIPTION	MAIN APPLICATION	RECOMMENDED DOSAGE	DENSITY (g/cm ³)
Mapeclean Recycler Admixture to recycle water used for rinsing cement trucks	Ready Mix	0.1kg/100 l of water	0.87 ± 0.01
Re-Con Zero Two-component powdered product used to recover leftover concrete directly from mixer trucks	Ready Mix	Comp A: 0.5 kg/m ³ Comp B: 6.0 kg/m ³	Comp A: 0.8 Comp B: 1.1
Re-Con Zero Booster Granulate booster	Ready Mix	6.5 kg/m ³	0.8

SUSTAINABLE RECOVERY OF RETURNED CONCRETE

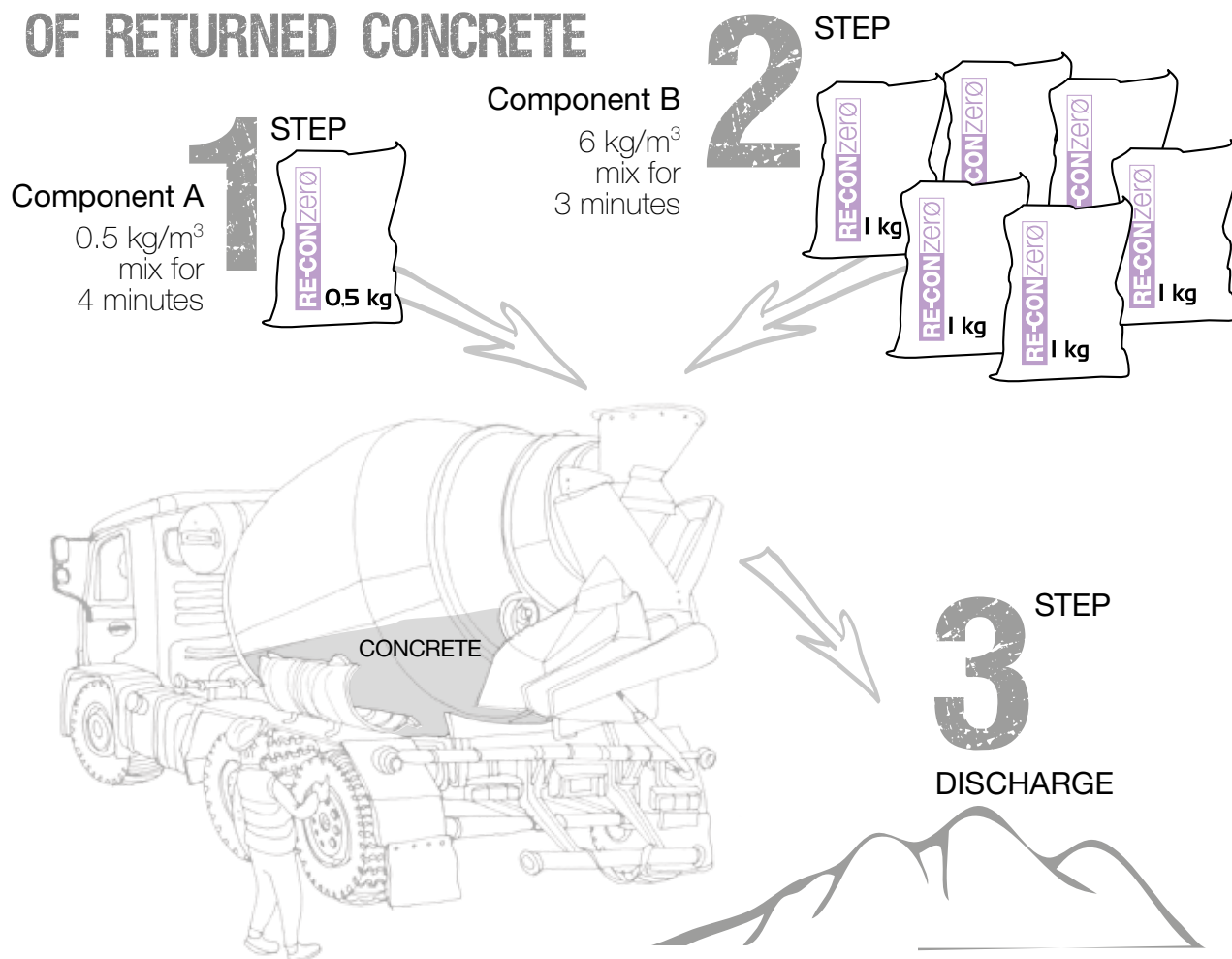

Complete kit to treat 1 cubic metre of returned concrete:
RE-CON ZERØ Component A: 1x0.5 kg water-soluble bag
RE-CON ZERØ Component B: 6x1 kg water-soluble bags

Surface curing compounds

All types of concrete must be cured for at least seven days after pouring to guarantee they develop the specified physical and mechanical characteristics. The use of surface curing agents guarantees that curing is carried out more efficiently over a longer period without having to resort to conventional, laborious damp-curing techniques, such as moistening the surroundings with fine mist and covering the concrete with temporary waterproof sheets.

PRODUCT / DESCRIPTION	MAIN APPLICATION	RECOMMENDED DOSAGE	DENSITY (g/cm ³)
<i>Mapecure E</i> Surface-film curing compound in water emulsion to protect the surface of concrete against rapid evaporation of the mixing water	Precast - Site use	70-100 g/m ²	0.94 ± 0.02
<i>Mapecure S</i> Solvent surface-film curing compound to protect the surface of concrete against rapid evaporation of the mixing water	Precast - Site use	100-110 g/m ²	0.91 ± 0.02
<i>Mapecure CA</i> Surface-film curing compound, which may be painted over, to protect the surface of concrete against rapid evaporation of the mixing water	Precast - Site use	110-150 g/m ²	0.98 ± 0.02

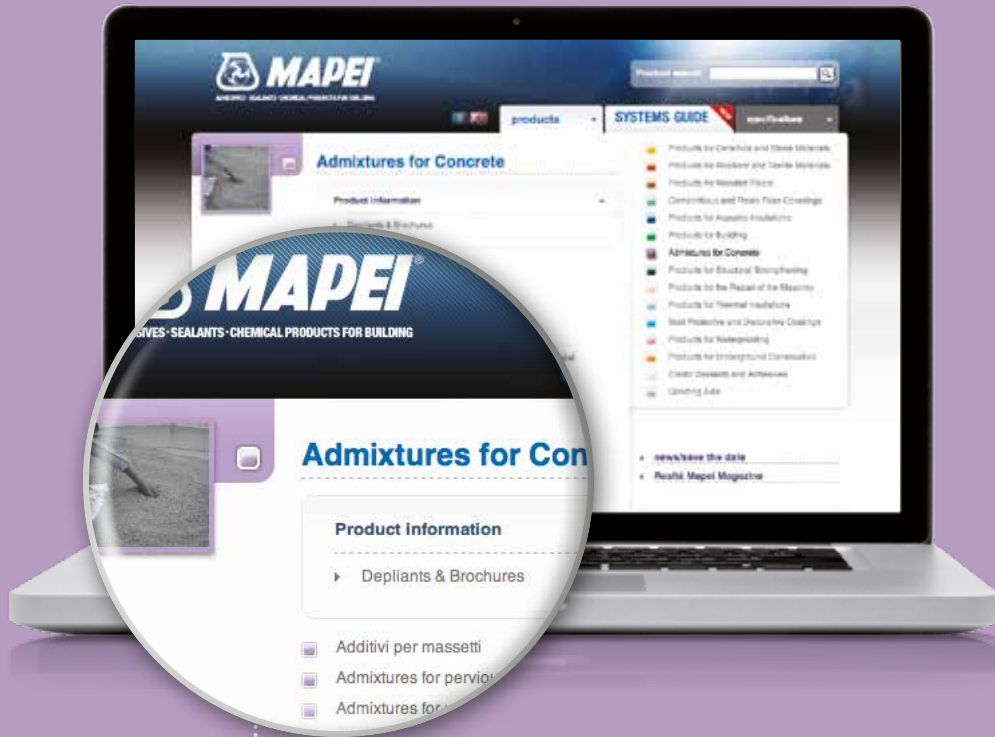

● **Technical documentation**

From the technical area menu you can view the technical documentation divided per product lines and type of document.

HEAD OFFICE
Mapei S.p.A.
Via Cafiero, 22 - 20158 Milan (Italy)
Tel. +39-02-37673.1
Fax +39-02-37673.214
www.mapei.com
mapei@mapei.it